

DS1 SERIES INSTRUCTION MANUAL

AREAscan™

CONTROLS

OUT LED on receiver (RX)
The yellow LED ON indicates the presence of the object into controlled area.

POWER ON LED on receiver (RX)
The green LED ON indicates the optimal device functioning. The fast blinking of the green LED indicates a critical device alignment. Please refer to "DIAGNOSTICS" paragraph for other indications.

POWER ON LED on emitter (TX)
The green LED ON indicates the correct device functioning. Please refer to "DIAGNOSTICS" paragraph for other indications.

INSTALLATION MODES

General information on device positioning

- Align the two receiver (RX) and emitter (TX) units, verifying that their distance is inside the device operating distance, in a parallel manner, placing the sensitive sides one in front of the other, with the connectors oriented on the same side. The critical alignment of the unit will be signalled by the fast blinking of the green receiver LED.

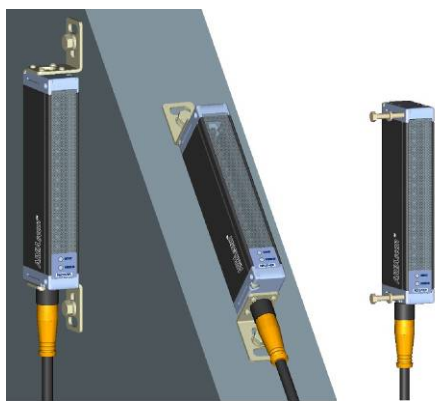

- Mount the receiver and emitter units on rigid supports which are not subject to strong vibrations, using specific fixing brackets and /or the holes present on the device lids.

Precautions to respect when choosing and installing the device

- Choose the device according to the minimum object to detect and the maximum controlled area requested (= operating distance x controlled height);
- In agroindustrial applications, the compatibility of light grid housing material and any chemical agents used in the production process has to be verified with the assistance of the DATASENSOR technical sales support department;
- The AREAscan™ light grids are NOT safety devices, and so MUST NOT be used in the safety control of the machines where installed.

Moreover the following points have to be considered:

- avoid installation near very intense and / or blinking light sources, in particular near to the receiver unit;
 - the presence of strong electromagnetic disturbances can condition the correct functioning of the device; this condition has to be carefully evaluated and checked with the DATASENSOR technical sales support department;
 - the presence of smoke, fog and suspended dust in the working environment can reduce the operating distance of the device;
 - strong and frequent temperature variations, with very low peak temperatures, can generate a thin condensation layer on the optics surfaces, compromising the correct functioning of the device;
 - reflecting surfaces near the luminous beam of the AREAscan™ device (above, under or lateral) can cause passive reflections able to compromise object detection inside the controlled area.
- if different devices have to be installed in adjacent areas, the emitter of one unit must not interfere with the receiver of the other unit.

General information relative to object detection and measurement

For a correct object detection and / or measurement, the object has to pass completely through the controlled area; testing the correct detection before beginning the process is suggested.

CONNECTIONS

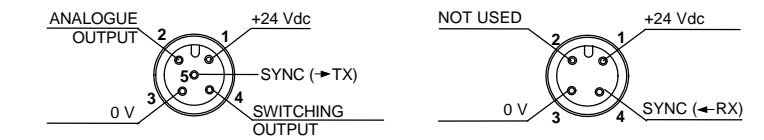

RECEIVER (RX): M12 5-pole connector		EMITTER (TX): M12 4-pole connector	
1 - brown:	+24 Vdc	1 - brown:	+24 Vdc
2 - white:	Analogue output	2 - white:	Not used
3 - blue:	0 V	3 - blue:	0 V
4 - black:	Switching output	4 - black:	SYNC
5 - grey:	SYNC		

Shielded cables are not foreseen in the standard connection.

Ground connection of the two units is not necessary. If desired, this connection can be accomplished replacing the screw provided in the packaging with the one indicated in the drawing, which blocks the lid of the connector side of each unit.

It is necessary to respect the connection shown in the drawing if ground connection of the entire system is requested.

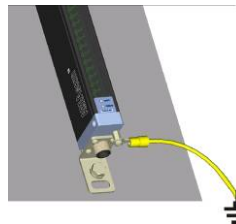

FUNCTIONING AND PERFORMANCES

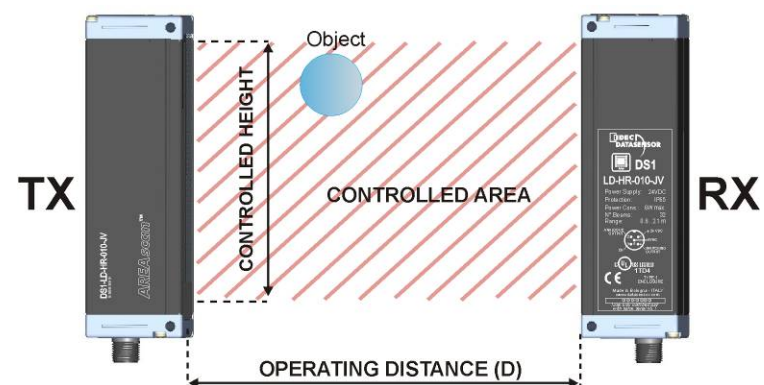

The beam interruption due to the passage of an object inside the controlled area caused the closing of the switching output and the variation of the device analogue output signal. Small objects can be detected (reaching dimensions of only 5 mm) and determine linear measurements with a ±3 mm error in best cases.

In particular:

The switching output is always activated when at least one beam is obscured. The status variation is signalled by the yellow receiver LED that turns on.

The analogue output value (0-10 V) is proportional to the number of obscured beams (0V means that no beam is interrupted, 10V all beams interrupted)

The device does not require calibration; periodical checks of the resolution and / or measurement are however suggested.

The blinking of the green receiver LED (*stability function*) signals the critical alignment of the units and / or the functioning outside or near the maximum operating distance. In optimal conditions the LED remains on continuously.

The two units are synchronised via cable (SYNC wire); precarious connections or induced disturbances on the synchronism line can cause device malfunctioning or a temporary blocking.

The diagrams, given below, show the typical minimum resolution trend of each model, SR (standard resolution) and HR (high resolution), in according to the operating distance (D).

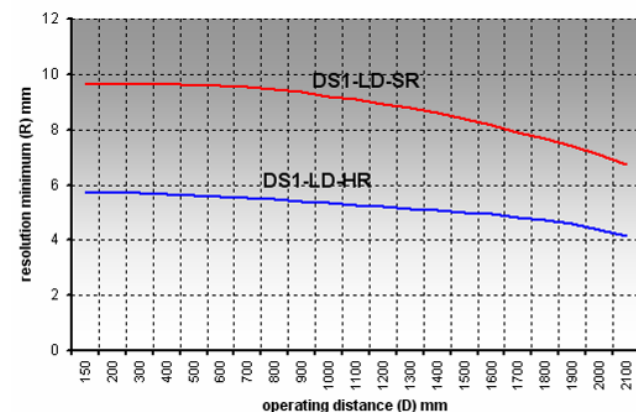

TECHNICAL DATA

Power supply:	24 Vdc ± 15%
Consumption on emitting unit (TX):	150 mA max.
Consumption on receiving unit (RX):	50 mA max without load
Switching output:	1 PNP output
Switching output current:	100 mA; short-circuit protection
Output saturation voltage:	≤ 1.5 V at T=25 °C
Analogue output:	0-10V proportional to obscured beams
Analogue output current:	10 mA max. (1KΩ proportional to obscured beams)
Minimum resolution:	5 mm (refer to "Specifications" table)
Measurement precision:	± 3.5 mm (refer to "Specifications" table)
Response time:	1 ms (refer to "Specifications" table)
Indicators:	RX: OUT LED (yellow) / POWER ON LED (green) TX: POWER ON LED (green)
Operating temperature:	0...+ 55 °C
Storage temperature:	-25...+ 70 °C
Operating distance (typical values):	0.15 - 2.1 m
Emission type:	Infrared (880 nm)
Vibrations:	0.5 mm amplitude, 10 ... 55 Hz frequency, for every axis (EN60068-2-6)
Shock resistance:	11 ms (30 G) 6 shock for every axis (EN60068-2-27)
Housing material:	Black electro-painted aluminium
Lens material:	PMMA
Mechanical protection:	IP65 (EN 60529)
Connections:	M12 4-pole connector for TX M12 5-pole connector for RX
Weight:	300 g. (DS1-xx-010-xx) 340 g. (DS1-xx-015-xx) 510 g. (DS1-xx-030-xx)

DIAGNOSTICS

RECEIVING UNIT:

Signal	Status	Cause	Action
OUT LED	ON	Switching output. Presence of the object in the controlled area.	
OUT LED	OFF	Switching output. Controlled area free of objects.	
POWER ON LED	ON	Optimal functioning	
POWER ON LED	Fast blinking	Critical alignment of the unit or/and functioning closed to maximum operating distance.	
POWER ON LED	Slow blinking	Wrong connections and/or malfunctioning.	<ul style="list-style-type: none"> Verify the output connections and any short-circuits Switch OFF and switch ON the device. If condition persists, contact Datasensor.
POWER ON LED	OFF	Device is not powered.	<ul style="list-style-type: none"> Verify the connections. If condition persists, contact Datasensor.

EMITTING UNIT:

Signal	Status	Cause	Action
POWER ON LED	ON	Normal functioning of emission unit.	
POWER ON LED	Blinking	Unit malfunctioning	<ul style="list-style-type: none"> Switch OFF and switch ON the device. If condition persists, contact Datasensor.
POWER ON LED	OFF	Absence of powering and/or synchronism with receiver	<ul style="list-style-type: none"> Verify the connections and right value of power supply. If condition persists, contact Datasensor.

SPECIFICATIONS

Model	Controlled height (mm)	N°. beams	Minimum resolution (mm)	Output analogue sensitivity (V)	Measurement precision (mm)	Response time (ms)	Operative distance (m)
DS1-LD-SR-010-xx	100	16	7	0.63	± 7	1	0.15...2.1
DS1-LD-HR-010-xx	100	32	5	0.31	± 3.5	2	0.15...2.1
DS1-LD-SR-015-xx	150	24	7	0.42	± 7	1.5	0.15...2.1
DS1-LD-HR-015-xx	150	48	5	0.21	± 3.5	2.75	0.15...2.1
DS1-LD-SR-030-xx	300	48	7	0.21	± 7	2.75	0.15...2.1

DIMENSIONS

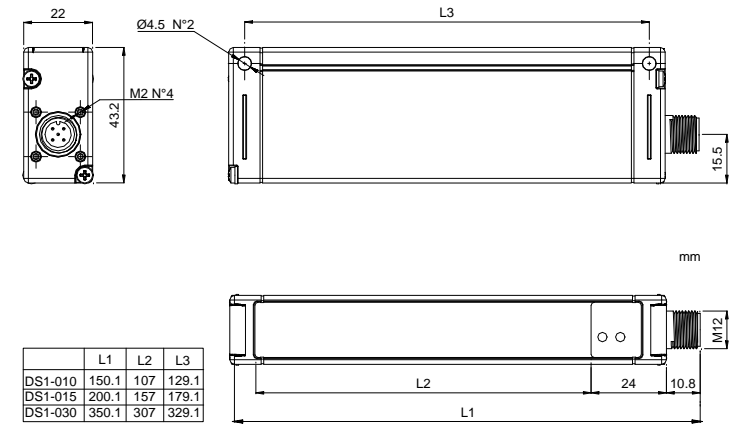

FIXING BRACKET

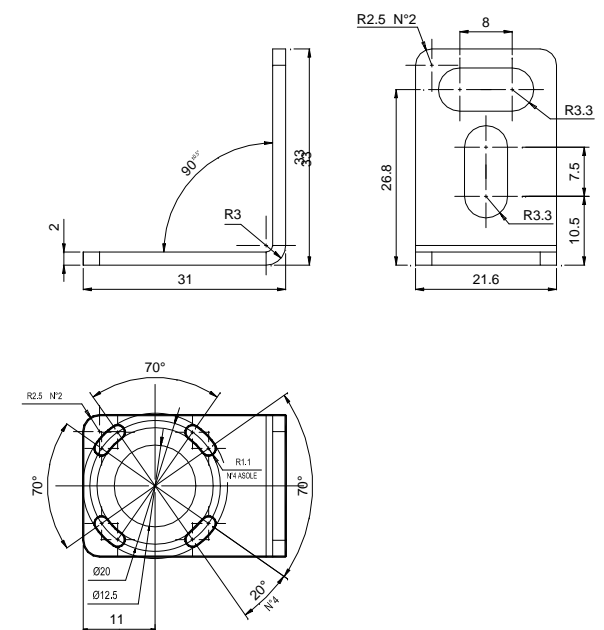

The fixing bracket is supplied with the product.

DECLARATION OF CONFORMITY

IDEC and DATASENSOR jointly declare under their sole responsibility that these products conform to the 2004/108/CE, 2006/95/CE Directives, and successive amendments.

IDEC and DATASENSOR reserve the right to make modifications and improvements without prior notification.